

Caterpillar 3208

FUEL INJECTION PUMP HOUSING AND GOVERNOR DISASSEMBLY & ASSEMBLY

• Remove Fuel Injection Pump Housing & Governor

TOOLS NEEDED		A	B
3P1544	Timing Pin	1	
5P2371	Plate		1
OS1616	Bolt ¼"20 NC x 1" long		2

Start By:

- Removing the air filter
- Removing the fuel injection lines
- Removing air inlet manifold

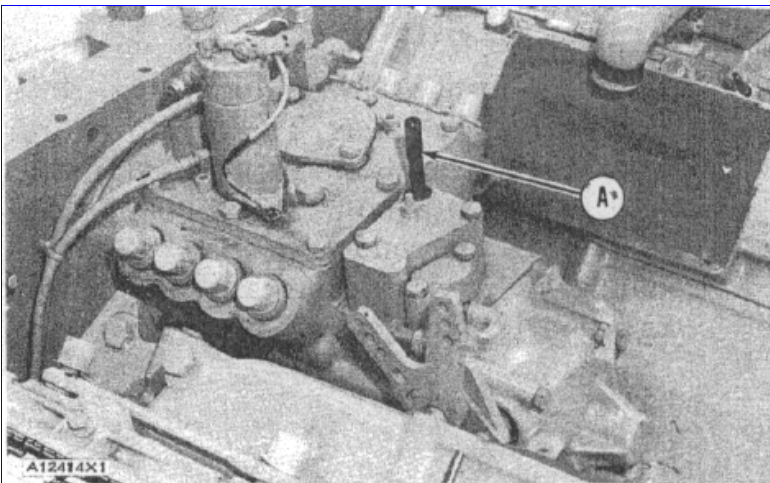

1. Remove plug from cover in fuel injection pump housing and install tool (A). Turn the crankshaft (clockwise) until the timing pin drops into the groove (slot) in the fuel injection pump camshaft.

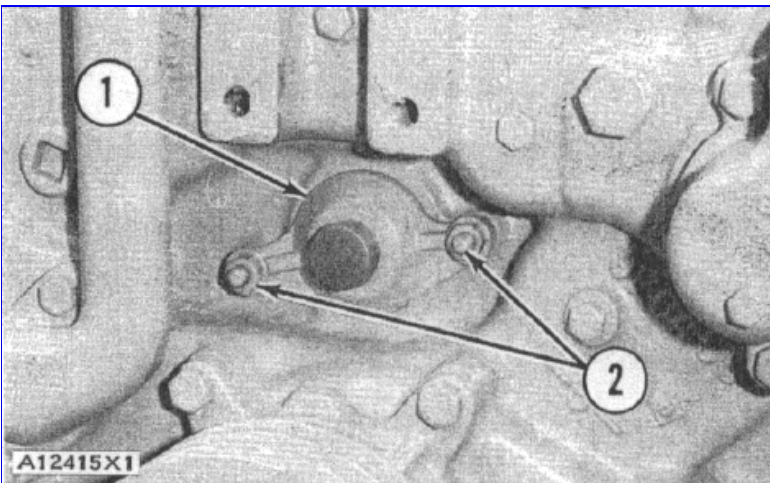

2. Remove two nuts (2) and the tachometer drive housing (1)

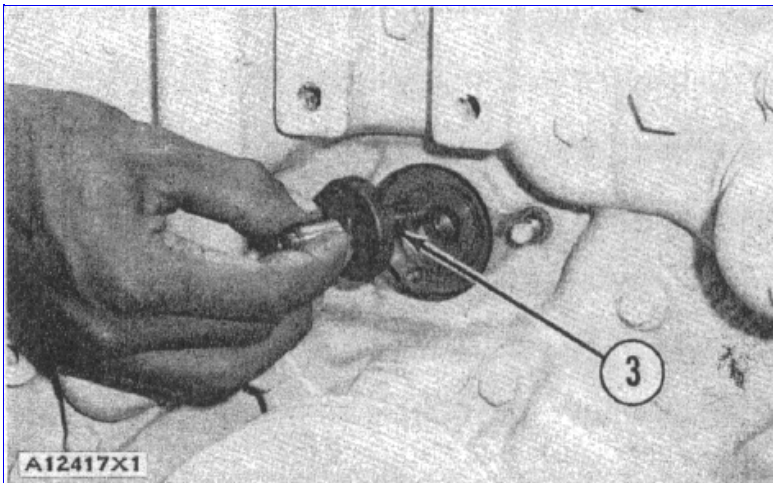

3. Remove tachometer drive shaft (3)

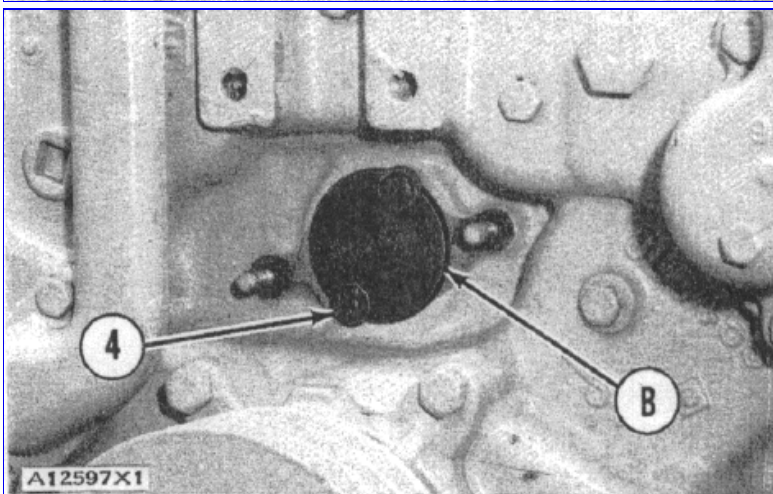

4. Install tooling (B) into the camshaft drive gear for the fuel injection pump. Turn bolts (4) evenly until the drive gear is free of the shaft. Remove tooling (B)

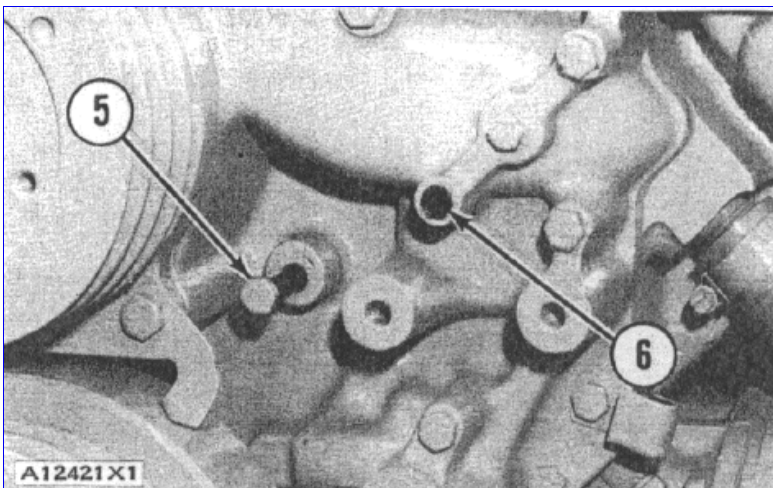

5. Remove the plug from the timing hole in the front cover and install a 5/16"-18 NC bolt (5) 2 1/2 in. long. The cover bolt from hole (6) can be used. Turn the crankshaft (clockwise) until bolt can be installed into timing hole. The camshaft for the fuel injection pump is now in correct time to the engine.

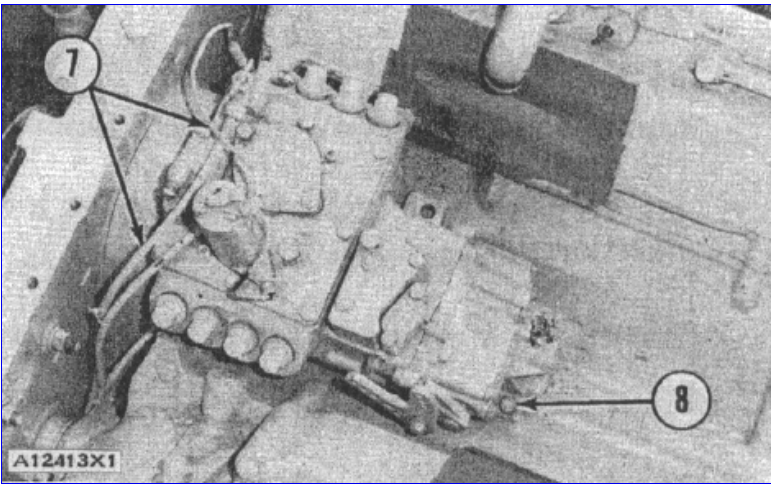

6. Remove line (7). Remove bolts (8) from base of the fuel injection pump housing.

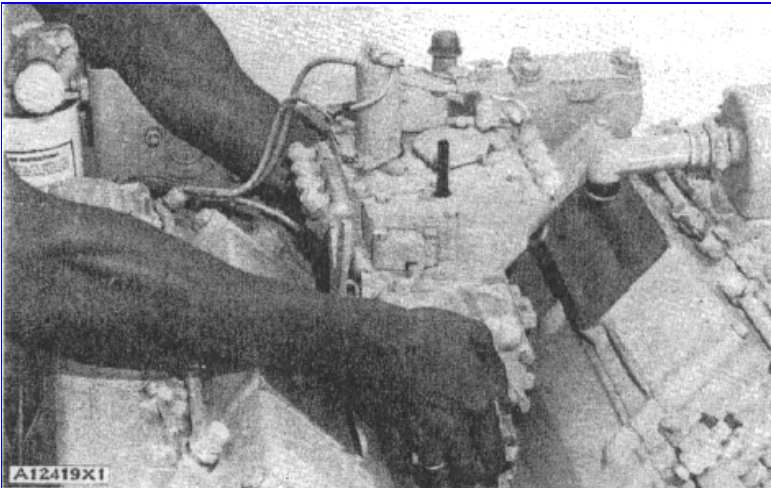

7. Remove the fuel injection pump housing and governor as a unit.

• Install Fuel Injection Pump Housing & Governor

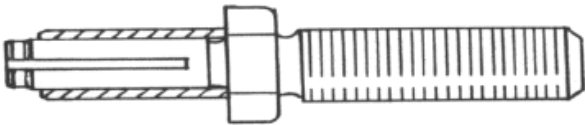

1. Put the fuel injection pump housing and governor in position on the engine. Install the bolts and lines.
2. Install the tachometer drive shaft and tighten it to a torque of . See page 4 for torque spec.
3. To check the timing, remove the timing pin and the bolt. Turn the crankshaft (clockwise) two revolutions and install the timing pin and bolt back in place. If the timing pin or bolt cannot be installed, the fuel injection pump camshaft must be put into time again before step 4 is done.
4. Remove the bolt from the timing gear. Install the plug into the timing hole.
5. Remove the timing pin from the timing groove (slot) in the fuel injection pump camshaft
6. Install the tachometer drive housing.

End By:

- a) Installing air inlet manifold
- b) Installing fuel injection lines
- c) Installing air cleaner

**DRIVE GEAR FOR THE INJECTION PUMP
(EARLIER BOLT)**

80 +/- 5 LB FT

- (1) Torque for the bolt that holds the drive gear to the camshaft of the injection pump 80 ± 5 lb. ft. (110 ± 7 N·m)

NOTE: Do not tighten the earlier bolt to the torque for the later bolt.

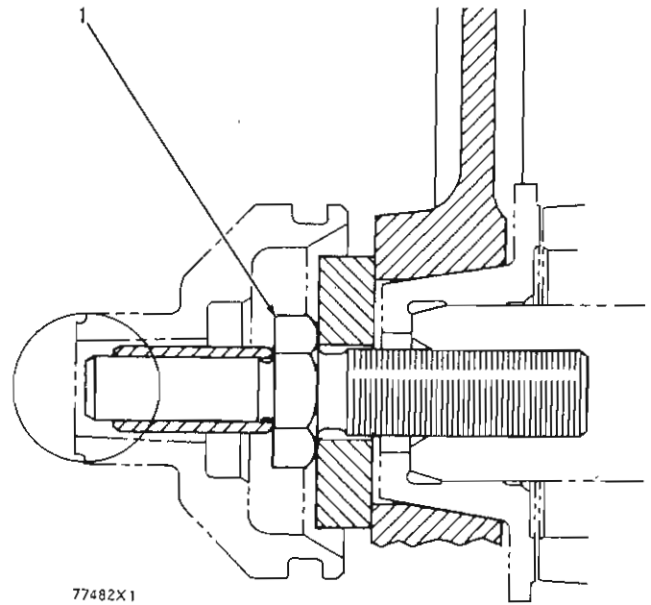

**DRIVE GEAR FOR THE INJECTION PUMP
(LATER BOLT)**

110 +/- 10 LB ft

- (1) Torque for the bolt that holds the drive gear to the camshaft of the injection pump 110 ± 10 lb. ft. (149 ± 14 N·m)

